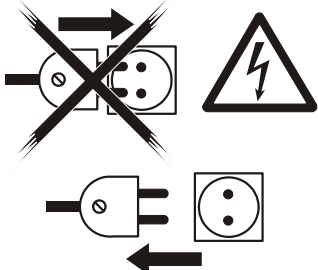
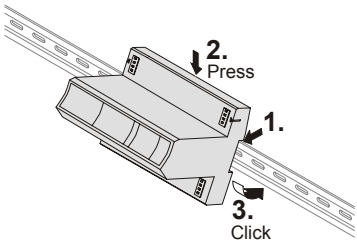
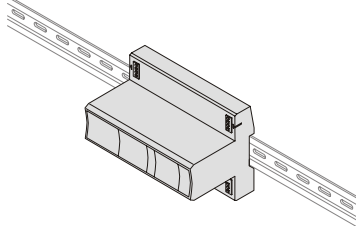
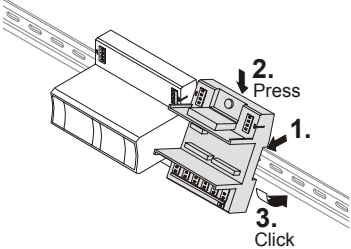
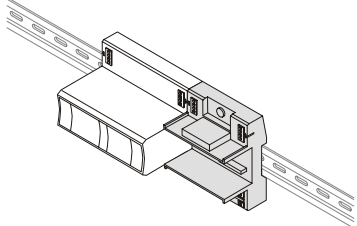
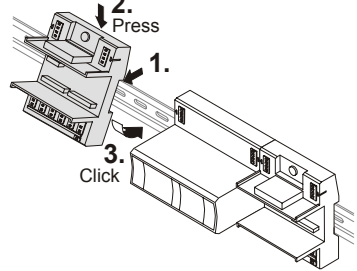
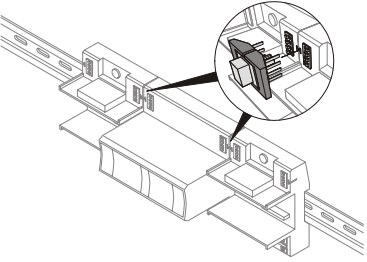
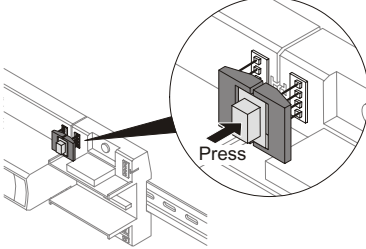
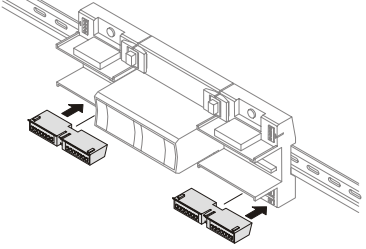
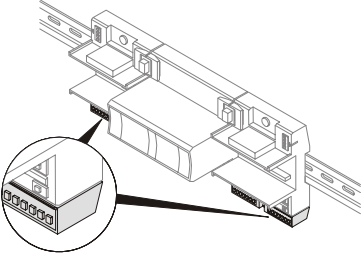
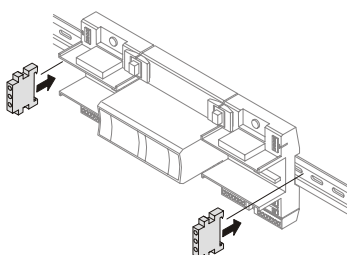
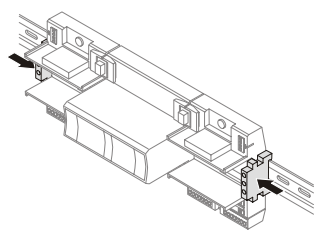
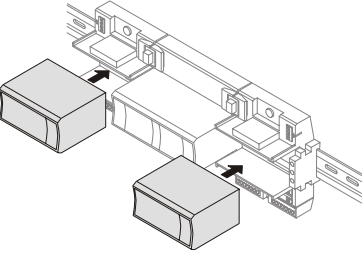
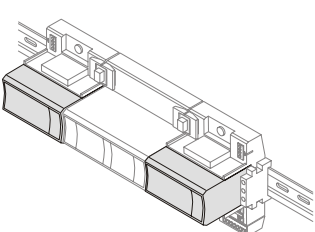
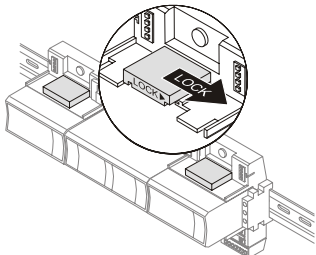
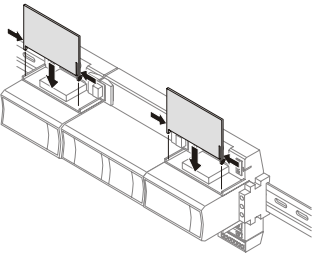
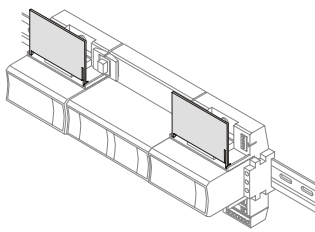
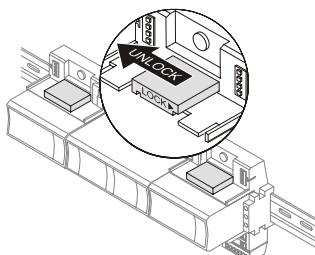
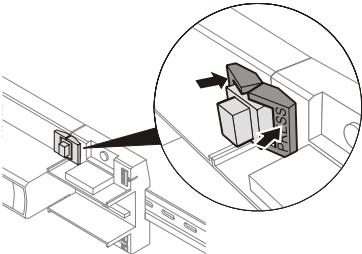
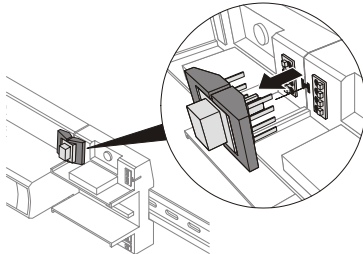
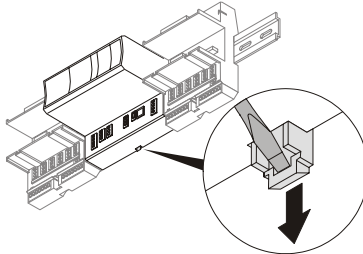
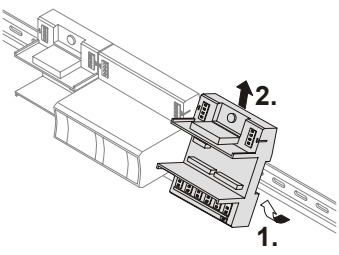
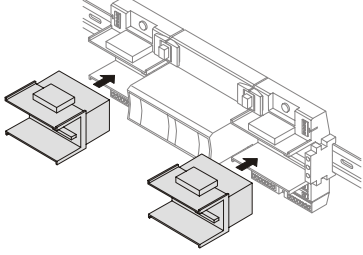
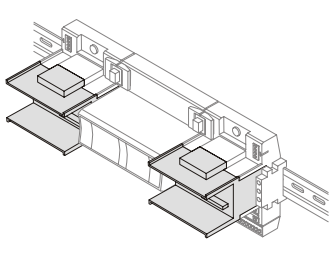
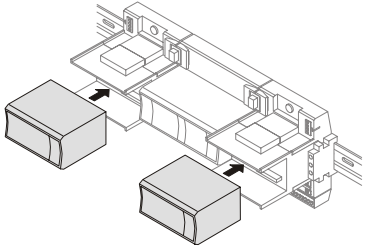
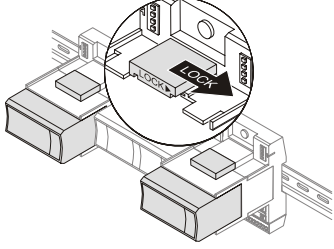
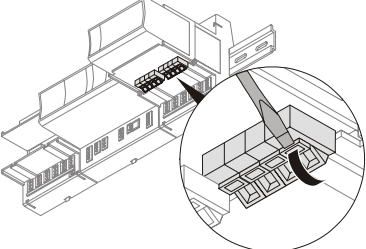
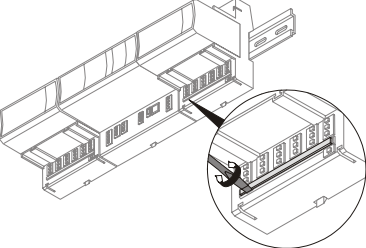
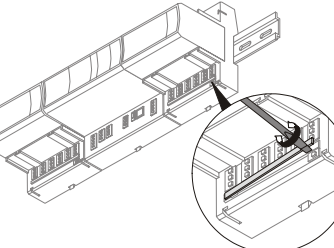
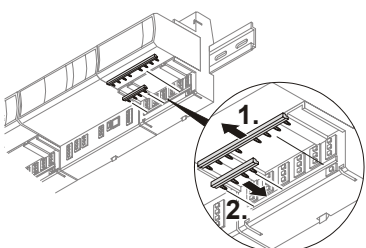
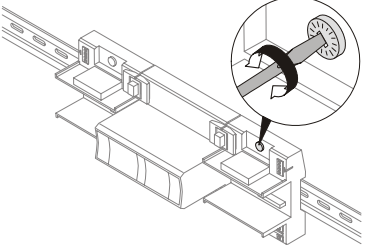
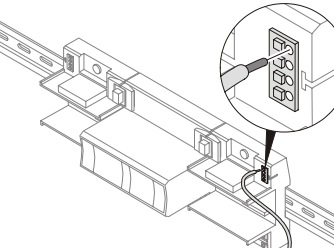
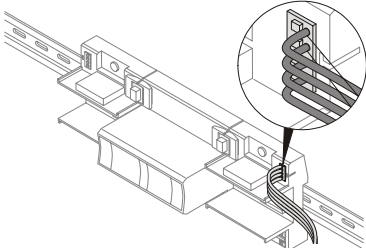
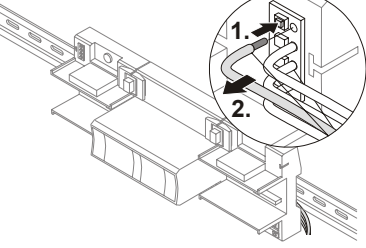

- D Montageanweisung
- DK Installationsvejledning
- ES Instrucciones de montaje
- F Instructions d'installation
- I Istruzioni di montaggio
- N Installationsinstruktioner
- NL Installatievoorschrift
- P Instruções de montagem
- S Installation instruktioner
- FI Asennusohje

MOUNTING INSTRUCTIONS

<p>E Keep these instructions together with the device or with the equipment documentation! Only qualified personnel may perform electrical connections for 230 VAC.</p>	<p>F Cette instruction est à conserver avec le contrôleur ou avec la documentation de l'installation ! Le raccordement électrique de servo-moteur pour le 230 VAC ne peut être effectué que par le personnel autorisé.</p>	<p>P Guarde estas instruções junto do regulador ou junto da documentação da instalação! A ligação eléctrica do actuador a 230 VAC só deve ser efectuada por pessoal especializado.</p>
<p>D Diese Anleitung ist beim Gerät oder in der Anlagen-dokumentation aufzubewahren! Elektrisches Anschließen von Antrieben für 230 VAC ist nur durch autorisiertes Fachpersonal gestattet.</p>	<p>I Queste istruzioni devono essere conservate insieme al lettore o con la documentazione dell'impianto! I collegamenti a 230VCA devono essere eseguiti da personale qualificato.</p>	<p>S Denna instruktion skall förvaras tillsammans med regler eller anläggningsdokumentationen! Elektrisk anslutning av ställdon med 230 VAC får endast utföras av behörig personal.</p>
<p>DK Opbevar denne vejledning sammen med regler eller med anlæggsdokumentationen! Elektrisk tilslutning af motorer for 230 VAC bør kun foretages af autoriserede personer.</p>	<p>N Denne vejledningen skal opbevares sammen med regler eller anlæggsdokumentationen! Elektrisk tilkopling av motorer med 230 VAC må kun utføres av fagfolk.</p>	<p>FI Tätä ohjetta tulee säilyttää laitteen läheisyydessä tai yhdessä muiden dokumenttien kanssa! Vain asianmukaiset oikeudet omaava henkilö saa suorittaa 230 VAC käyttöjännitteen liittäöitä.</p>
<p>ES Conserve estas instrucciones con el recalar o con la documentación de la instalación. La conexión eléctrica del actoador a 230 VCA debe hacerse solamente por personal cualificado.</p>	<p>NL Deze handleiding moet bij de regelaar, of met de documentatie van de installatie worden bewaard! De elektrische aansluiting van servomotoren voor 230 VAC mag alleen door geautoriseerd personeel worden uitgevoerd.</p>	
<p>0: Before Installation</p> 	<p>A1: Mounting Controller</p> 	<p>A2: Controller Mounted</p> 
<p>A3: Mounting Right Socket at the Right</p> 	<p>A4: Right Socket Mounted</p> 	<p>A5: Mounting Socket at the Left</p> 
<p>A6: Mounting Bridge Connectors, Step 1</p> 	<p>A7: Mounting Bridge Connectors, Step 2</p> 	<p>A8: Mounting xx814 (Optional)</p> 

<p>A9: xx814 (Optional) Mounted</p> 	<p>A10: Mounting Stoppers (Optional), Step 1</p> 	<p>A11: Mounting Stoppers (Optional), Step 2</p> 
<p>A12: Mounting Electronic Modules</p> 	<p>A13: Electronic Modules Mounted</p> 	<p>A14: Locking Electronic Modules</p> 
<p>A15: Mounting Label Holders</p> 	<p>A16: Label Holders Mounted</p> 	<p>A17: Unlocking Electronic Modules</p> 
<p>A18: Dismounting Bridge Conn., Step 1</p> 	<p>A19: Dismounting Bridge Conn., Step 2</p> 	<p>A20: Dismounting Socket, Step 1</p> 
<p>A21: Dismounting Socket, Step 2</p> 	<p>A22: Mounting xx812/RO (Optional), Step 1</p> 	<p>A23: xx812/RO (Optional) Mounted</p> 

<p>A24: Mounting xx812/RO (Optional), Step 2</p> 	<p>A25: Mounting xx812/RO (Optional), Step 3</p> 	<p>A26: Operating Disconnecter Switches</p> 
<p>A27: Unmounting Cross Conn. (Opt.), St. 1</p> 	<p>A28: Unmounting Cross Conn. (Opt.), St. 2</p> 	<p>A29: Changing Cross Connectors (Opt.)</p> 
<p>A30: Setting Hex Switch</p> 	<p>A31: Wiring Extra Modules</p> 	<p>A32: Extra Modules Wired</p> 
<p>A33: Unwiring Extra Modules</p> 		

E	Wiring	N	Ledningsnett
D	Verkabelung	NL	Bedrading
DK	Ledninger	P	Cablagem
ES	Cableado	S	Kablage
F	Câblage	FI	Kaapelointi
I	Cablaggio		

WIRING

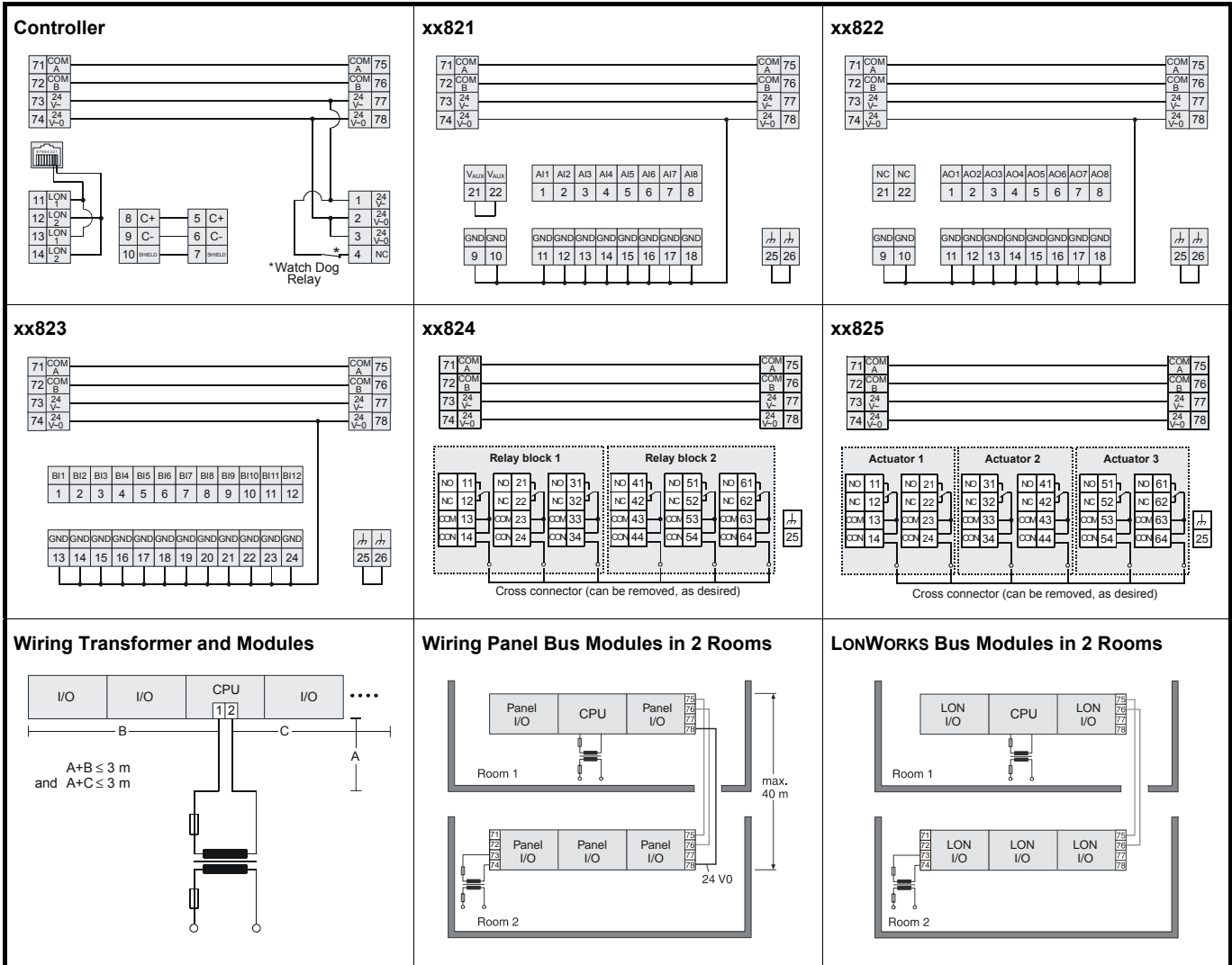

Manufactured for and on behalf of the Environmental and Combustion Controls Division of Honeywell Technologies Sàrl, Ecublens, Route du Bois 37, Switzerland by its Authorized Representative:

Automation and Control Solutions

Honeywell GmbH
 Böblinger Straße 17
 D-71101 Schönaich / Germany
 Phone: (49) 7031 637 - 01
 Fax: (49) 7031 637 - 493
<http://europe.hbc.honeywell.com>

Subject to change without notice. Printed in Germany
 EN1B-0359GE51 R0507B

**DIN EN ISO
 9001/14001**